

Stretch wrapping

Automatic wrapping machine GL 1000

The economical
alternative to protect
and stabilize pallets



STRETCH WRAPPING

Stretch wrapping has become very popular over the last few years. This is a specially developed technique to provide a stable and economical securement of pallets. Its principle is much like a rubberband's stretchability. A stretch wrapper stretches the film up to several hundred percent before it is applied on the pallet. The pre-stretching of the film makes it thinner but also stronger.

Every time the pallets under transport get jolted in a lorry, the film contracts and stabilizes the pallets even more. It keeps away dust and moisture and by using a top sheet, the upper side of the goods can be protected.

GL 1000

The GL 1000 is an automatic pallet stretchwrapper with powered conveyor. GL 1000 is able to fulfill the highest demands regarding capacity, adaptability from customer to customer and is easy to serve and economical. GL 1000 will become the perfect fully automatic wrapping station in your packaging line.

The GL 1000 is equipped with a unit which prestretches the film. With a programmable operating system the turn-and-lift speed, the amount of film, the wrap tension etc. can be adjusted so that it is applicable to a large variety of loads to meet your requirements precisely.

The GL 1000 is delivered programmed according to your needs. The equipment such as conveyors or turntable can be operated from one and the same operating panel, which saves room.



ADVANTAGES OF GL 1000

- Building measures – saves space
- Mechanics – easy to serve
- Constant prestretch adjustable in 7 steps – guarantees film consumption
- Automatic change of film tension to fit varying types of goods and different film types
- Optional cutting height – high capacity and low film consumption
- Prestretch unit design – easy to change film roll
- Easy to handle – operating panel with digital display
- Design

TECHNICAL SPECIFICATION

Stretchwrapper	Capacity	50 – 70 pallets/hour (depends on type of goods)
	Lowest conveyor height	375 mm
	Conveyor speed	Programmable
	Turntable speed	Maximum 20 rpm, programmable
	Lift speed	Maximum 0.3 m/s, programmable
	Sound level	< 70 dB(A)
Weight	1200 kg	
Electrical data	Supply	3x400 V+N+PE, 50 Hz, 20 A
	Loading	2.5 kW
	Protection	IP 54
Pneumatic supply	Compressed air (no lube)	at 6 bar
	Air flow rate	800 l/min (10 l/cycle)
Load handling Pallet sizes	Weight	Maximum 1.5 ton
	Height (incl. Pallet)	Maximum 2.5 m
	Length	0.5 – 1.4 m
	Width	0.5 – 1.2 m
	Conveyor width	1370 mm
	The stretchwrapper can be designed for larger loads.	
Film dimensions	Core diameter	76.4 mm
	Maximum diameter	230 mm
	Maximum film width	500 mm
	Film thickness	15 – 25 my

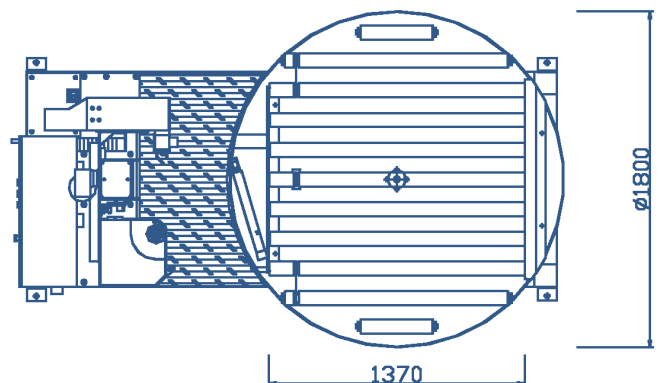
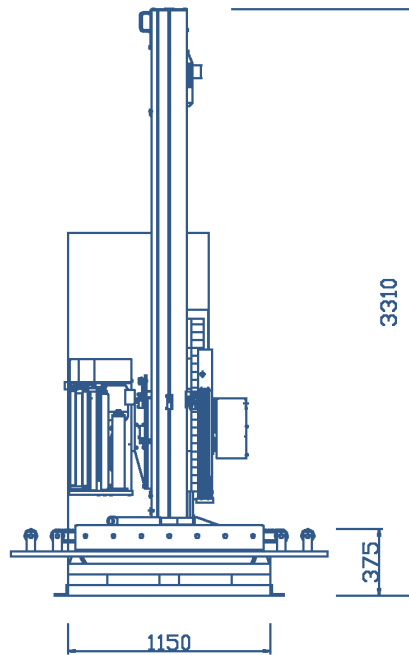
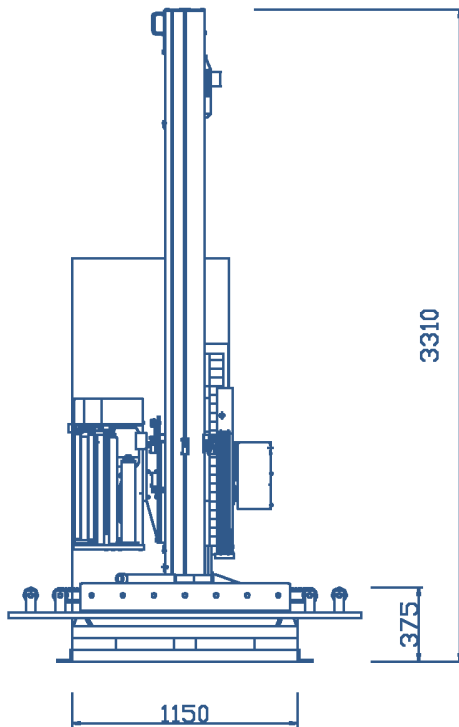



PRESTRETCH UNIT ECOSTRETCH

The stretch unit prestretches the film between two rollers rotating at different speeds through a mechanical connection, the exit roller being power assisted.

The exchange between the rollers is constant with stretch ratios in 7 steps between 60 and 300%. The choice of stretch grade depends upon the characteristics of the film, the sort of loads and the speed of the turntable.

The Cyklop stretch unit has become a success. With the help of an advanced electronic system, we can maintain a constant wrap tension between unit and pallets, regardless of the size and form of the pallets.

The film tension is chosen to fit the goods to be wrapped. This tension will change automatically if another film type is used. A low wrap tension is applicable to light and delicate loads while a high wrap tension is necessary for heavy, dense loads.

The unit is specially designed for easy and quick change of film.

ACCESSORIES

- Top platen for unstable goods and high capacity requirements
- Top sheet dispenser (different designs)
- Sheet dispenser for e.g. corrugated board
- Special conveyors
- Welding unit
- In and outtransport 90°
- Antistatic equipment
- Separate control unit
- Special designs can be offered

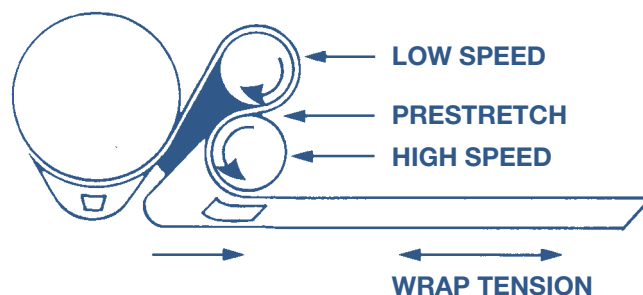

Subject to modification.